

TITLE:

SCAFFOLD RACK WELD

PART #

M6410008

DRAWING #

TMP1050

REVISION:

DATE: 2022-05-19

DRAWN BY: Terry Platteeuw

SHEET: 1 OF 5

APPROVED BY:

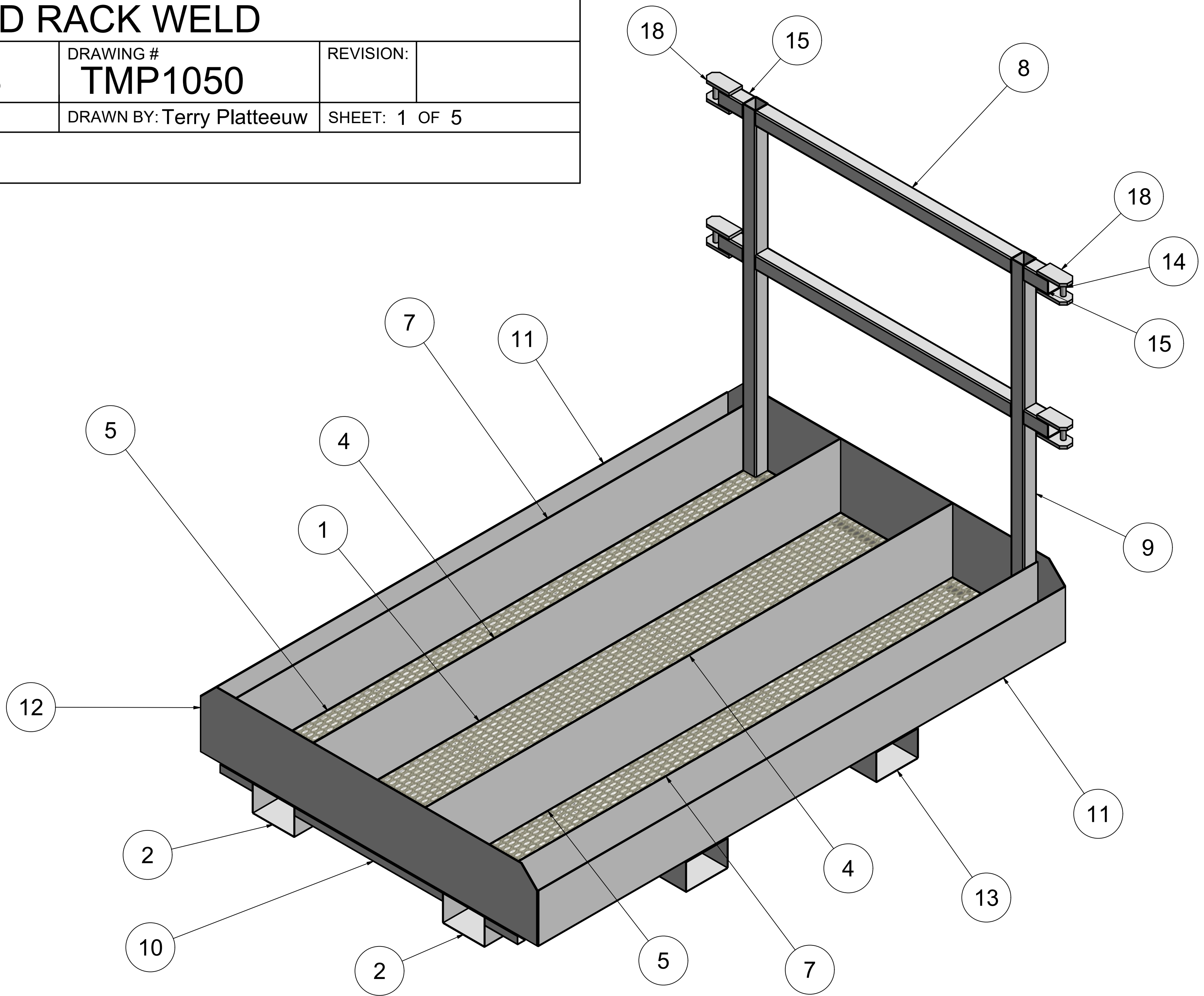

TITLE:
SCAFFOLD RACK WELD

PART #
M6410008

DRAWING #
TMP1050

REVISION:

SHEET: 2 OF 5

DATE: 2022-05-19

DRAWN BY: Terry Platteeuw

APPROVED BY:

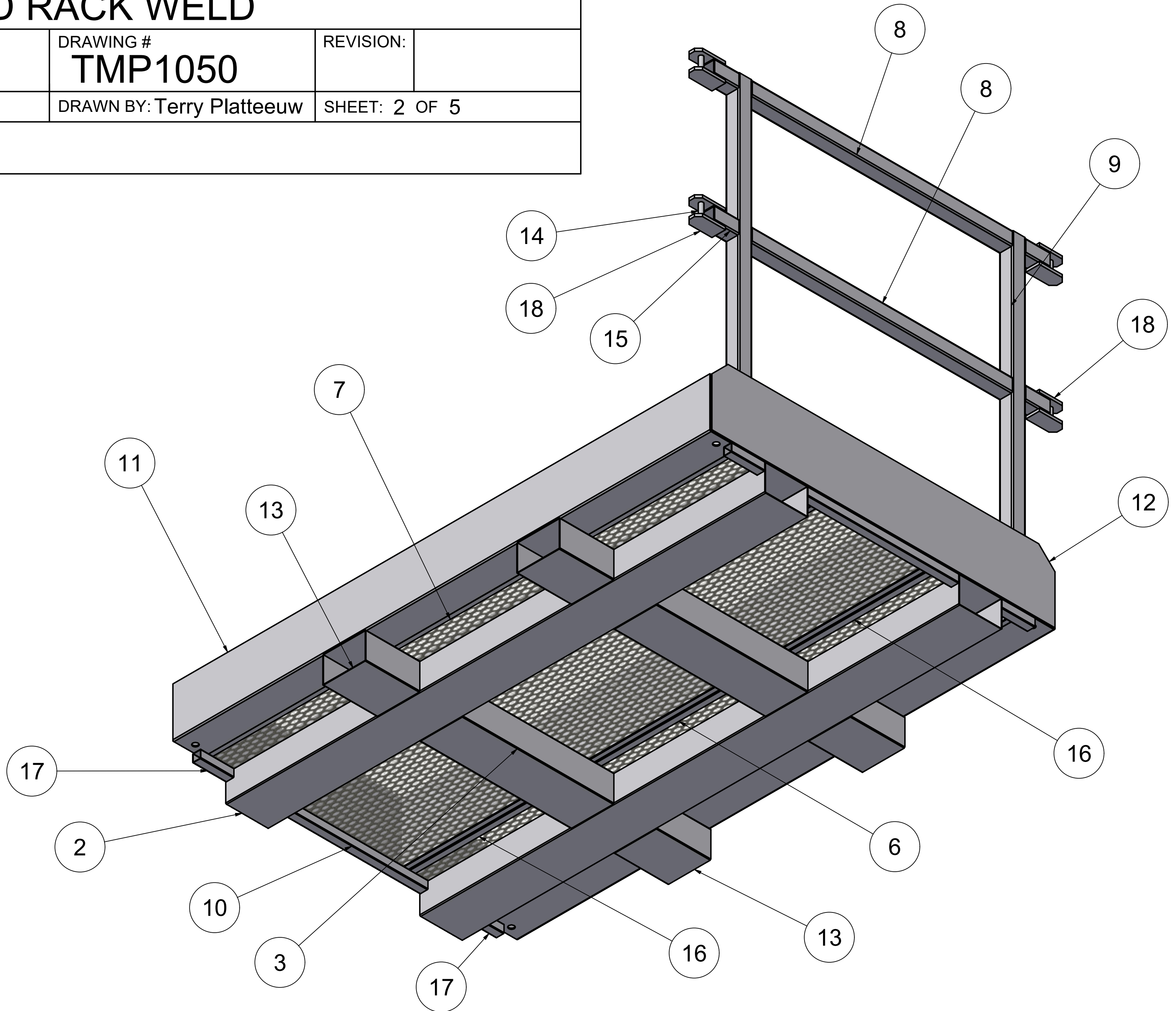

TITLE:
SCAFFOLD RACK WELD

PART #
M6410008

DRAWING #
TMP1050

REVISION:

DATE: 2022-05-19

DRAWN BY: Terry Platteeuw

SHEET: 3 OF 5

APPROVED BY:

NOTE:

- 1) WELD AS PER WJI-19-1
- 2) ALL DIMENSIONS - INCHES
- 3) ALL TOLERANCES +/- 1/16"

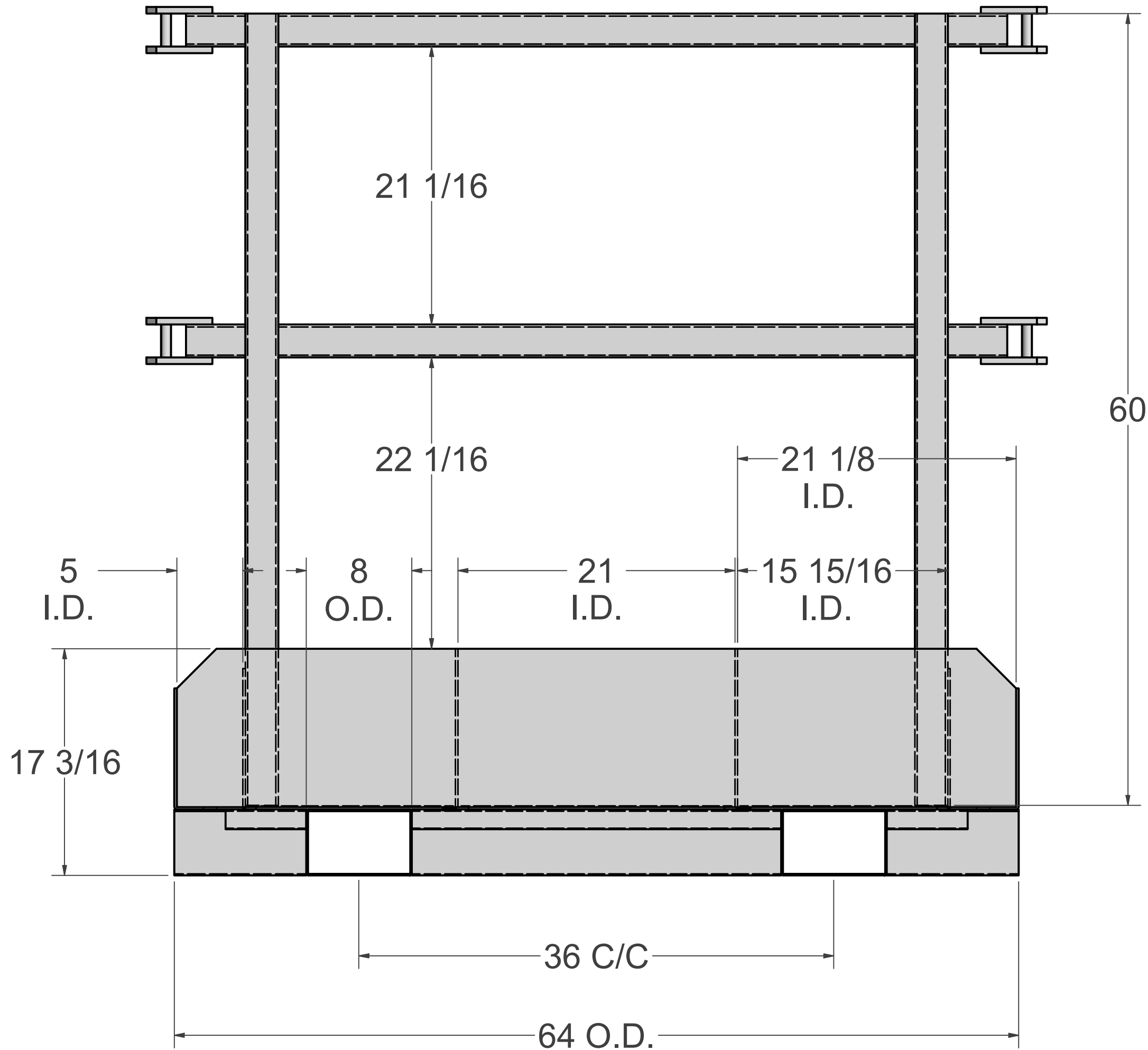

SCAFFOLD RACK WELD Parts List		
ITEM	QTY	DESCRIPTION
1	1	SCAFFOLD
1	1	CENTER MESH
2	2	FORK GUIDE LONG WELD
3	2	FORK GUIDE CENTER WELD
4	2	INNER WALL PLATE 2
5	2	END MESH
6	2	MESH SUPPORT FLAT BAR CENTER
7	2	INNER WALL PLATE
8	2	HORIZONTAL STRAP TUBE
9	2	VERTICAL STRAP TUBE
10	2	END TUBE - LONG
11	2	SIDE PLATE
12	2	END PLATE
13	4	FORK GUIDE END WELD
14	4	STRAP ROUND BAR
15	4	HORIZONTAL STRAP TUBE - SHORT
16	4	MESH SUPPORT FLAT BAR END
17	4	END TUBE - SHORT
18	8	STRAP BRACKET

TITLE:

SCAFFOLD RACK WELD

PART #

M6410008

DRAWING #

TMP1050

REVISION:

DATE: 2022-05-19

DRAWN BY: Terry Platteeuw

SHEET: 4 OF 5

APPROVED BY:

NOTE:

- 1) WELD AS PER WJI-19-1
- 2) ALL DIMENSIONS - INCHES
- 3) ALL TOLERANCES +/- 1/16"

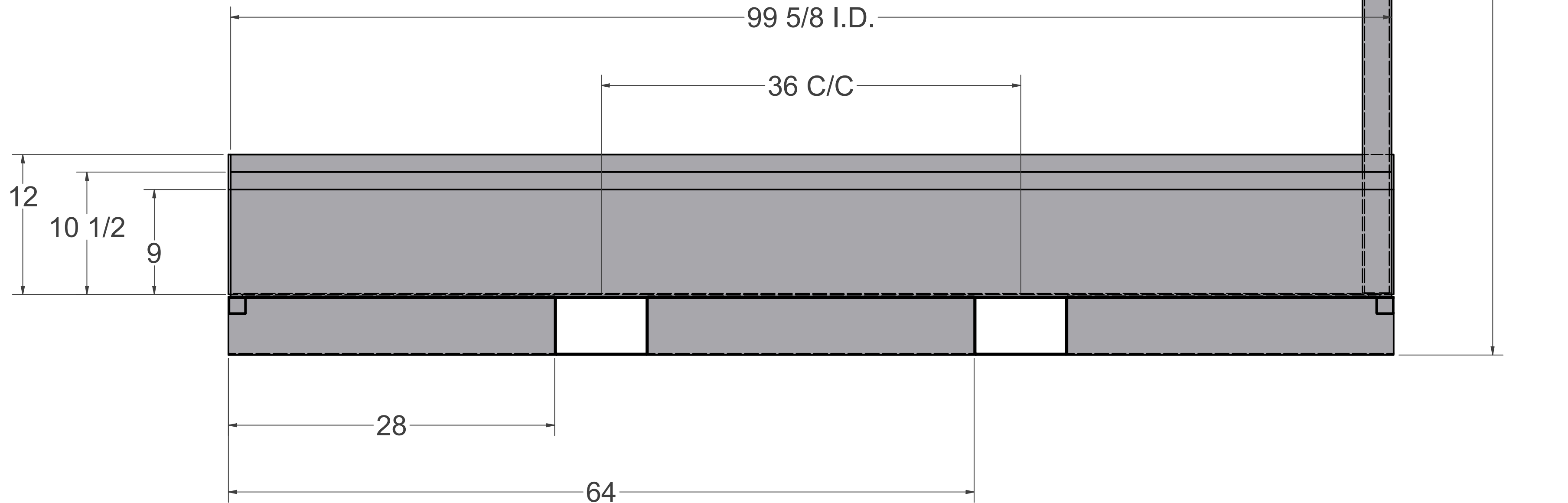

TITLE:
SCAFFOLD RACK WELD

PART #
M6410008

DRAWING #
TMP1050

REVISION:

DATE: 2022-05-19

DRAWN BY: Terry Platteeuw

SHEET: 5 OF 5

APPROVED BY:

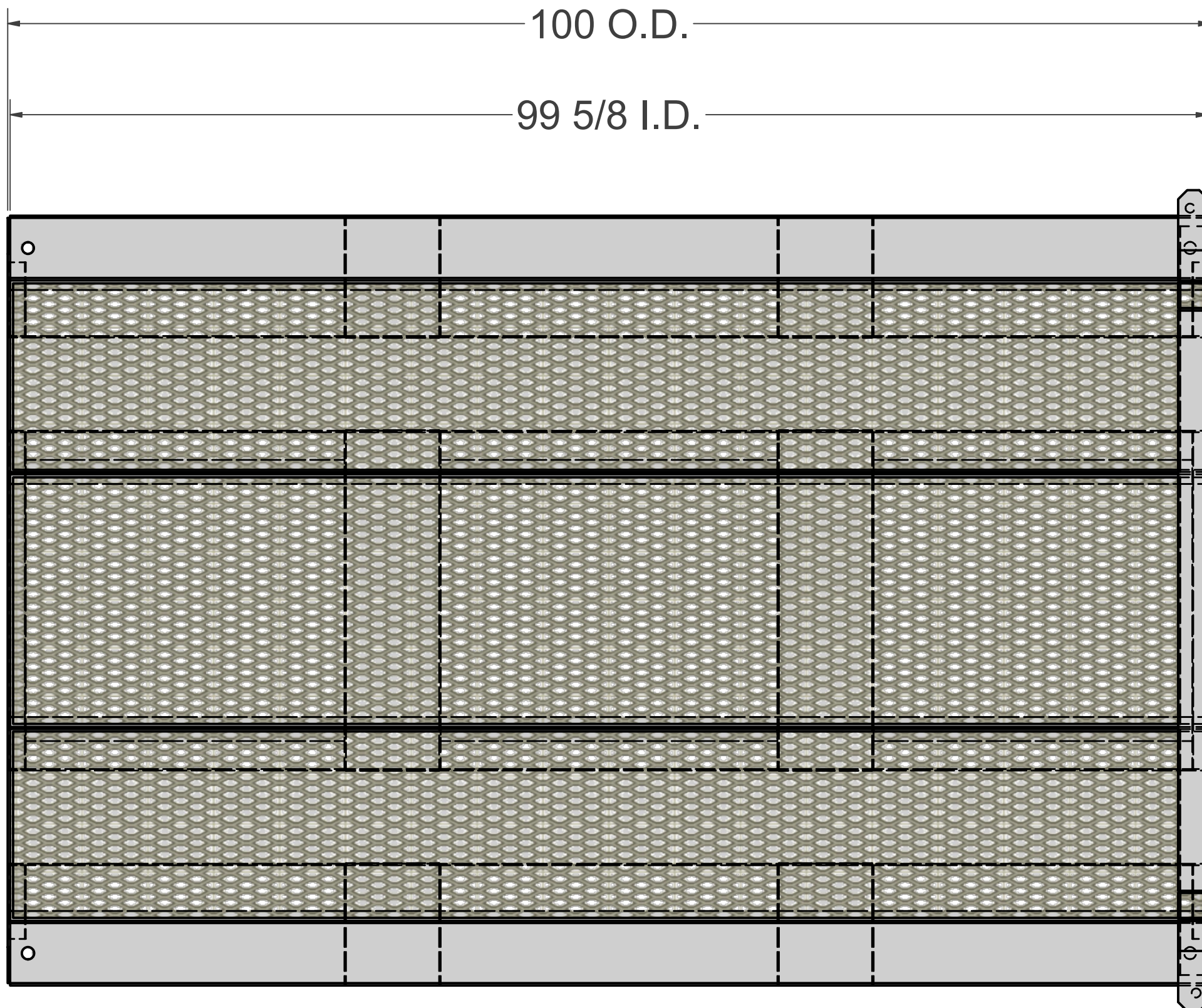
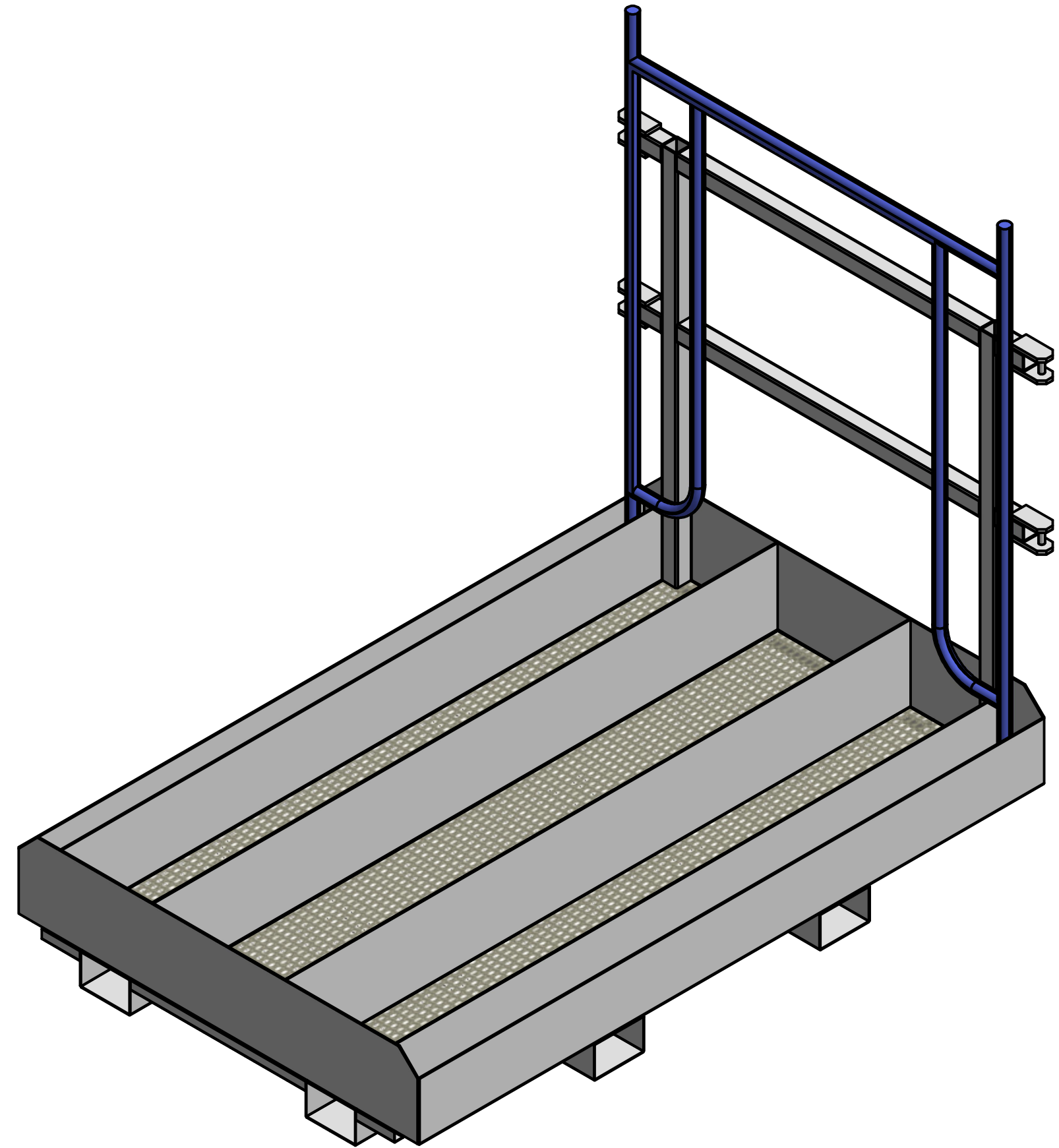

NOTE:
 1) WELD AS PER WJI-19-1
 2) ALL DIMENSIONS - INCHES
 3) ALL TOLERANCES +/- 1/16"